

NextGen

Industrial Doors

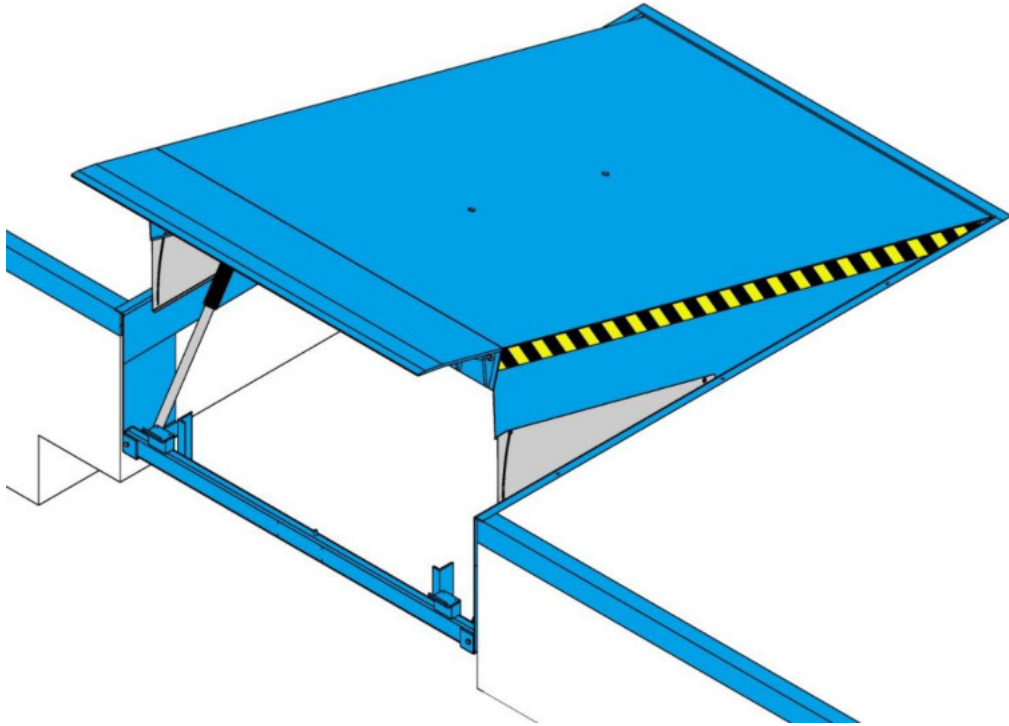

Product datasheet

Hydraulic dock leveller with swing lip

Type: PS2

Load capacity: 60 kN

Contents

- General information3
 - Overview.....3
 - Standard parameters4
 - Options4
 - Design characteristics.....4
- Swing lip.....5
 - Standard swing lip5
 - Swing lip options.....5
- Platform.....7
 - Tear-plate thickness.....7
 - Toe guards7
 - EPDM sealing.....8
 - Anti-slip / anti-noise coating8
 - Platform insulation8
- Surface treatment.....9
 - Painting.....9
- Hydraulic unit9
- Frames / pits10
 - T frame (to be embedded in concrete)10
 - W frame (in combination with a pre-frame)11
 - F frame (flat steel frame for leveller replacement)12
 - P frame (mounted in the pit).....13
 - B (box).....14
- Control units15
- Accessories.....16
 - Buffers16
 - Fixed-position buffers.....16
 - Height-adjustable buffers17
 - Floating buffers17
 - Buffers with protective housing18
 - Spring-steel buffer18
 - Wheel chock19
 - Traffic lights19
 - Dock light.....19
 - Wheel guides19
- Electrical preparations (by others)20

General information

The stationary dock leveller with swing lip (PS2) is a new product of PROMStahl's wide product range. This top-quality product benefits from over 25 years of experience in designing and manufacturing docking systems. The electro-hydraulic PS2 leveller is operated at the touch of a button. As soon as the platform has reached its highest position the lip swings out automatically and comes to rest on the lorry bed. During loading and unloading the PROMStahl dock leveller follows the movements of the vehicle (automatic floating position). The PS2 dock leveller is supplied including frame and installed in the pit as a compact unit in just one step. Additional supports are not necessary. Considerable savings in installation and its tail-lift recess, i.e. the possibility to accommodate tail lifts, are the big advantages of this system. The load capacity of the PS2 dock leveller corresponds to the axle load limit taking into consideration the most unfavourable loading case. The PROMStahl dock leveller meets the requirements of the most recent European standards (EN 1398).

Overview

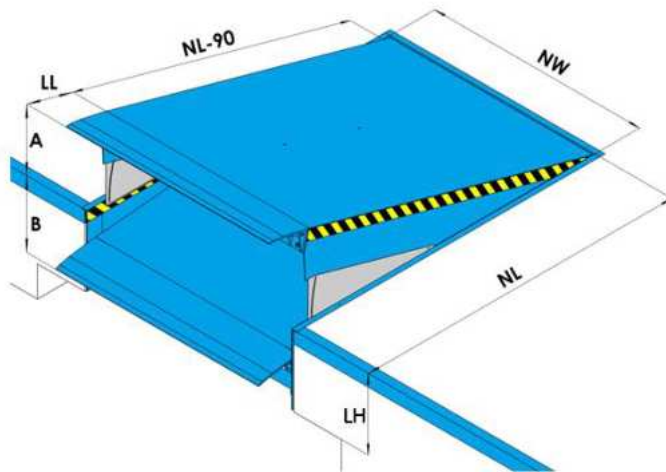

- NL Nominal length
- NW Nominal width
- LL Lip length
- LH Leveller height
- A Level equalisation above dock
- B Level equalisation below dock

In accordance with the EN 1398 standard, the leveller must not be used beyond the permissible gradient range of $\pm 12.5\%$ (about $\pm 7^\circ$). The limits may only be exceeded if the operator ensures that the danger of slipping has been eliminated (e.g. due to dry and clean surfaces).

Dock leveller		LL=400		LL=500	
NL	LH	A	B	A	B
1750	700	250	325	185	345
2000	600	290	270	-	-
	700	290	350	190	340
2500	600	360	260	-	-
	700	380	315	260	325
2750	600	330	260	-	-
	700	390	310	275	320
3000	600	305	255	-	-
	700	450	305	305	315
3500	800	380	325	310	310
4000	900	570	300	460	300
4500	900	530	290	430	300
Nominal width (NW) 1750, 2000, 2100, 2200, 2250, 2400 for all sizes.				All dimensions in mm	
Load capacity for all sizes: 60 kN (dynamic), 84 kN (static)					
Further load capacities and sizes on request.					

Standard parameters

Swing lip	Angled swing lip, lip length: 400 mm Chamfered section: 40 mm Tear-plate thickness: 13 mm/15 mm
Platform	Tear-plate thickness: 6 mm/8 mm
Frame	T frame (leveller frame to be embedded in concrete) W frame (in combination with a pre-frame) F frame (flat-steel frame, for leveller replacement) Pit frame (only for pits without tail-lift) B frame (Box)
Surface	Painted, standard colours: RAL 5010, RAL 7016, RAL 9005
Hydraulic unit	Hydraulic unit: 0.75 kW - 2 lift cylinders with emergency stop valve - 1 lift cylinder for the swing lip Standard oil (-20°C to +60°C)
Control unit	Control unit (with auto button)

Options

Swing lip	Angled swing lip: lip length: 500 mm (only for LH ≥ 700), chamfered section: 100 mm Straight swing lip: lip length: 400 mm/ 500 mm, chamfered section 40 mm/ 100 mm Swing lip with fold-down segments (125 mm on each side, only for lip length 400 mm) Swing lip with tapered edges (125 mm on both sides) Swing lip „FALL GUARD“
Platform	Tear-plate thickness: 8 mm/10 mm
Frame	Special
Surface	Painting in different RAL colours and various layer thicknesses Hot-dip galvanisation
Hydraulic oil	Organic oil (-20°C to + 60°C) Low-temperature oil (- 30°C to + 40°C)
Control unit	Special control unit with additional options
Others	EPDM sealing Anti-slip / anti-noise coating Platform insulation: ISO panel (thickness: 40 mm, 60 mm)

Design characteristics

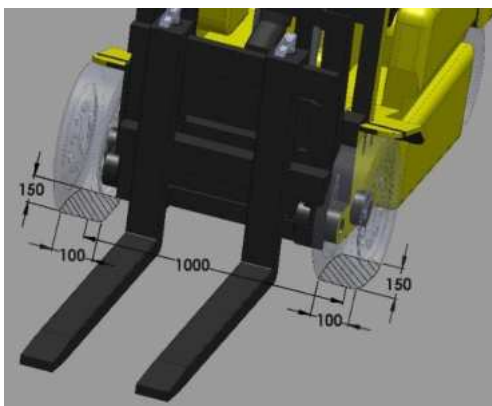

The PS2 dock leveller meets all requirements of the EN 1398 standard. The standard load capacity of 60 kN (dynamic axle load) corresponds to the EN 1398 standard for a forklift wheel contact surface of 100x150 mm. Higher concentrated loads as well as higher load capacities are available on request.

Swing lip

Standard swing lip

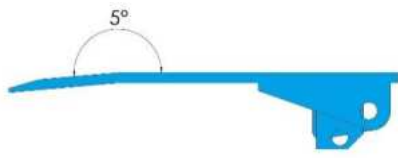

For a standard load capacity of 60 kN the angled swing lip consists of 13/15 mm tear plate material (S235JRG2). The front part of the lip is bent by 5° for ergonomic reasons and provided with a 40 mm chamfered section. Thanks to this feature loading and unloading by means of low-wheelbase vehicles is possible without any problems. Other designs can of course be delivered on request. Trouble-free operation is guaranteed due to the easily accessible, low-maintenance swing lip which needs no cleaning.

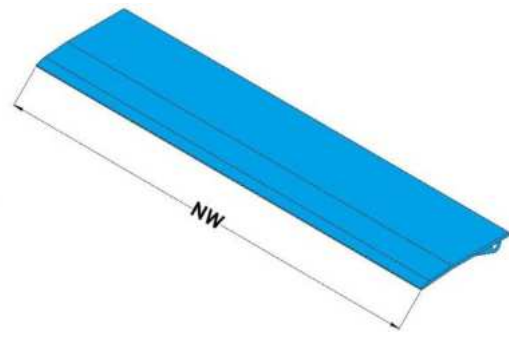

Swing lip options

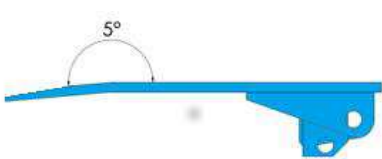

Chamfered section: 100 mm

For ergonomic reasons the front part of the hinge lip is bent by 5° and provided with a 100mm chamfered section. Thanks to this feature, transition from the swing lip to the vehicle bed is even more comfortable.

Straight swing lip



The straight version of the swing lip is recommended if the vehicle lorry bed is lower than the ramp height, i.e. mainly negative level equalizations are required. In doing so, the transition from the hinge lip to the truck lorry bed is very smooth. A chamfered section of 40mm is recommended when loading / unloading vehicles with big and soft wheels are used. A chamfered section of 100mm is more suited for loading / unloading vehicles with small and hard wheels.

Tapered lip

The most cost-effective way to reduce the contact area of the swing lip is to provide it with tapered edges on both sides. This option offers 125 mm bevels on both sides. Recommended for NW > 2,200 mm.

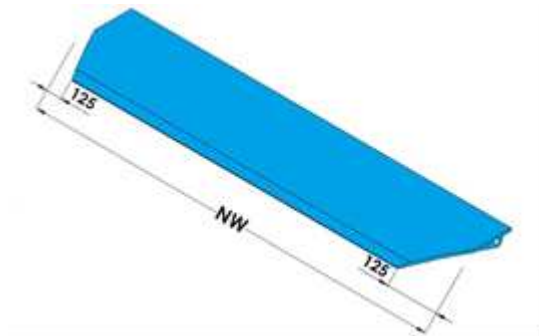

Fold-down segments

Our PS2 dock levellers are also available with fold-down segments. In this case the lip consists of a central element and two side elements (located on the left and right hand side). The side elements fold down independently of the central element. The lip width is reduced by 125 mm on each side so that vehicles with narrow beds can be also loaded and unloaded. When the lip returns to its rest position, the side elements are automatically locked with the central element so that the central element and the side elements are lifted together during the subsequent swing-out process.

Recommended for NW > 2200 mm. This option is only available for lip length: 400 mm.

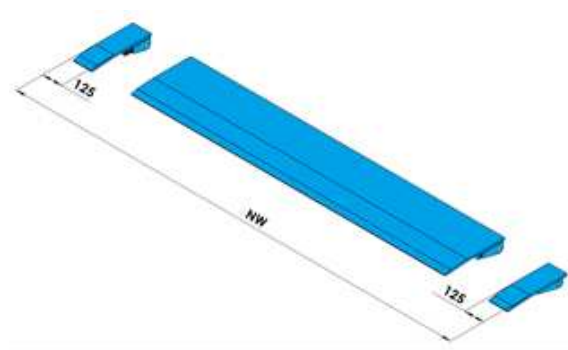

Swing lip „FALL GUARD“

The “FALL GUARD” hinge lip feature guarantees optimum safety for the loading personnel. When the dock leveller returns in its rest position, a 90mm section of the hinge lip is positioned vertically above the platform surface, thus creating an obstacle and preventing the fork lift truck and the warehouse personnel from falling from the ramp.

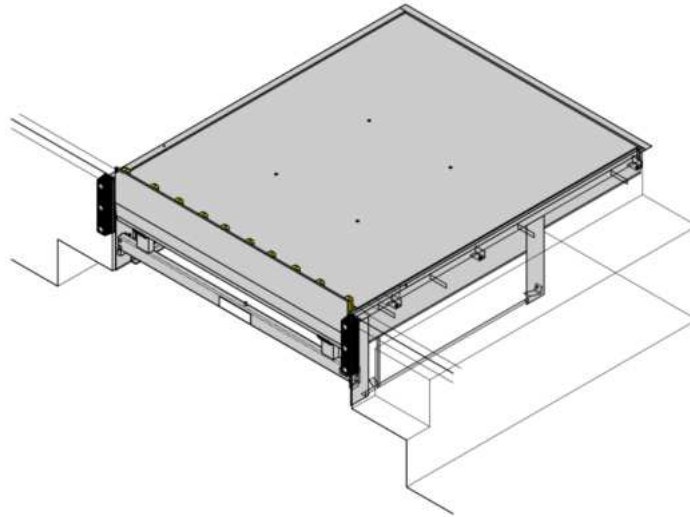

Platform

Tear-plate thickness

The platform is made of high-quality tear plate material (S235JRG2) and supplied with a thickness of 6/8 mm or optionally with 8/10 mm. It is strengthened by means of special reinforcements guaranteeing optimal stability as well as a sufficient transverse torsion strength of up to 10% of the platform's width.

Optimised connection between the platform and the lip guarantee safe operation and a long lifespan.

Toe guards

The dock leveller is always provided with lateral toe guards to prevent foot injuries when the leveller moves downwards.

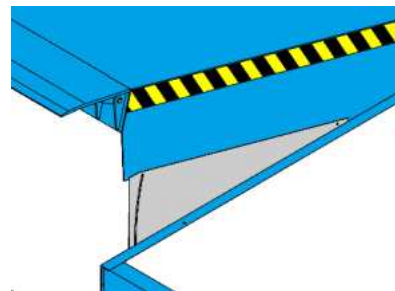

EPDM sealing

The EPDM sealing is used to seal the gap between the dock leveller and the pit so that draught in the warehouse building is reduced, the staff's working conditions are improved and energy can be saved. The EPDM sealing is installed on the three sides of the leveller.

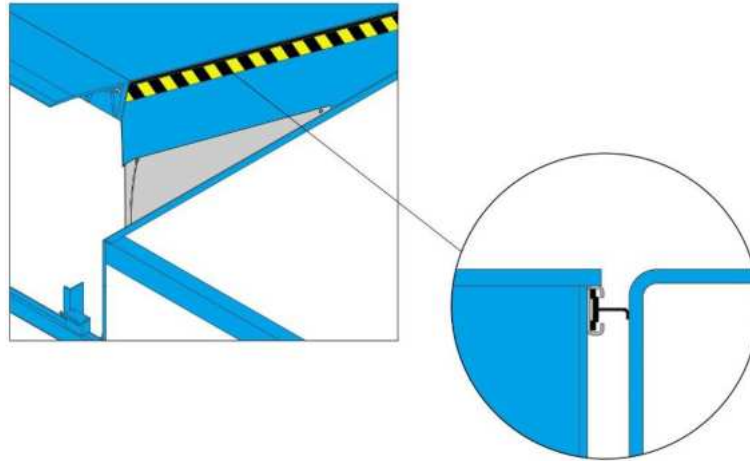

Anti-slip / anti-noise coating

As an option, it is possible to provide the platform and the swing lip with a special anti-slip / anti-noise layer. This coating consists of high-elasticity solvent-free polyurethane with a material thickness of 3-4 mm filled with sharp-edge broken basalt (grain size 1-1.6 mm).

This type of coating guarantees a high degree of anti-slip and anti-noise protection and is applied to profiled material. That's why the requirements of DIN EN 1398 regarding slip prevention are met even if this coating is damaged.

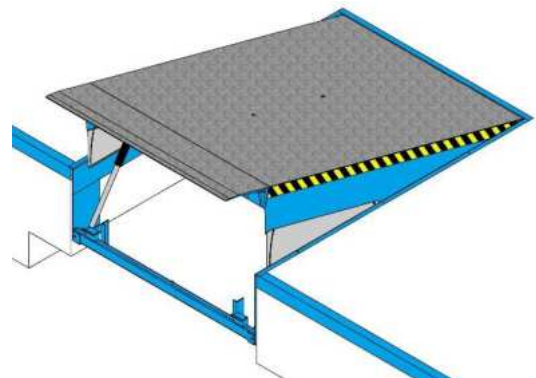

Platform insulation

In these days, energy saving is an important topic. Therefore, it is essential to optimally insulate the docking station. If the dock leveller is located outside the door opening, the platform insulation panel prevents cold or warm air from entering the warehouse inner area. The leveller platform is insulated by means of 40 mm or 60 mm insulation panels. To guarantee best possible sealing effect, it is recommended to combine the platform insulation with the EPDM sealing.

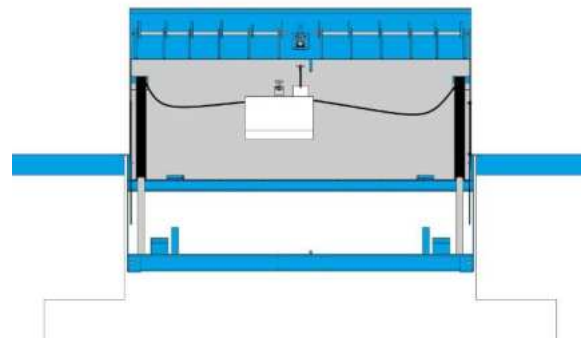

Surface treatment

Painting

Before final assembly, the individual components of the dock leveller are sandblasted and provided with a two-component paint. Standard RAL colours are RAL 5010, RAL 7016 and RAL 9005 in a layer thickness of 80 µm (corrosion protection class C2-M). Further RAL colours and layer thicknesses of up to 160 µm (corrosion protection class C3-H) are available as an option.

To increase corrosion protection, the dock leveller can also be delivered with hot-dip galvanized steel parts.

Hydraulic unit

The dock leveller is operated by means of a tried and tested hydraulic unit immersed in oil (0.75 kW). The closed system stands out for its high reliability even under very difficult operating conditions. We offer special hydraulic oils for use with low-temperature applications.

The dock leveller is lifted by means of two cylinders (Ø 40 mm) to ensure safe positioning even if the lorry leaves the dock during loading or unloading. In this case the down movement of the leveller has to be stopped; this is guaranteed by means of special emergency valves in the lift cylinders.

The lip is swung out by means of a lip cylinder with a piston rod of 30 mm in diameter.

Frames / pits

T frame (to be embedded in concrete)

The leveller is directly cast into concrete including its frame.
 Advantage: fast and clean installation in one step.

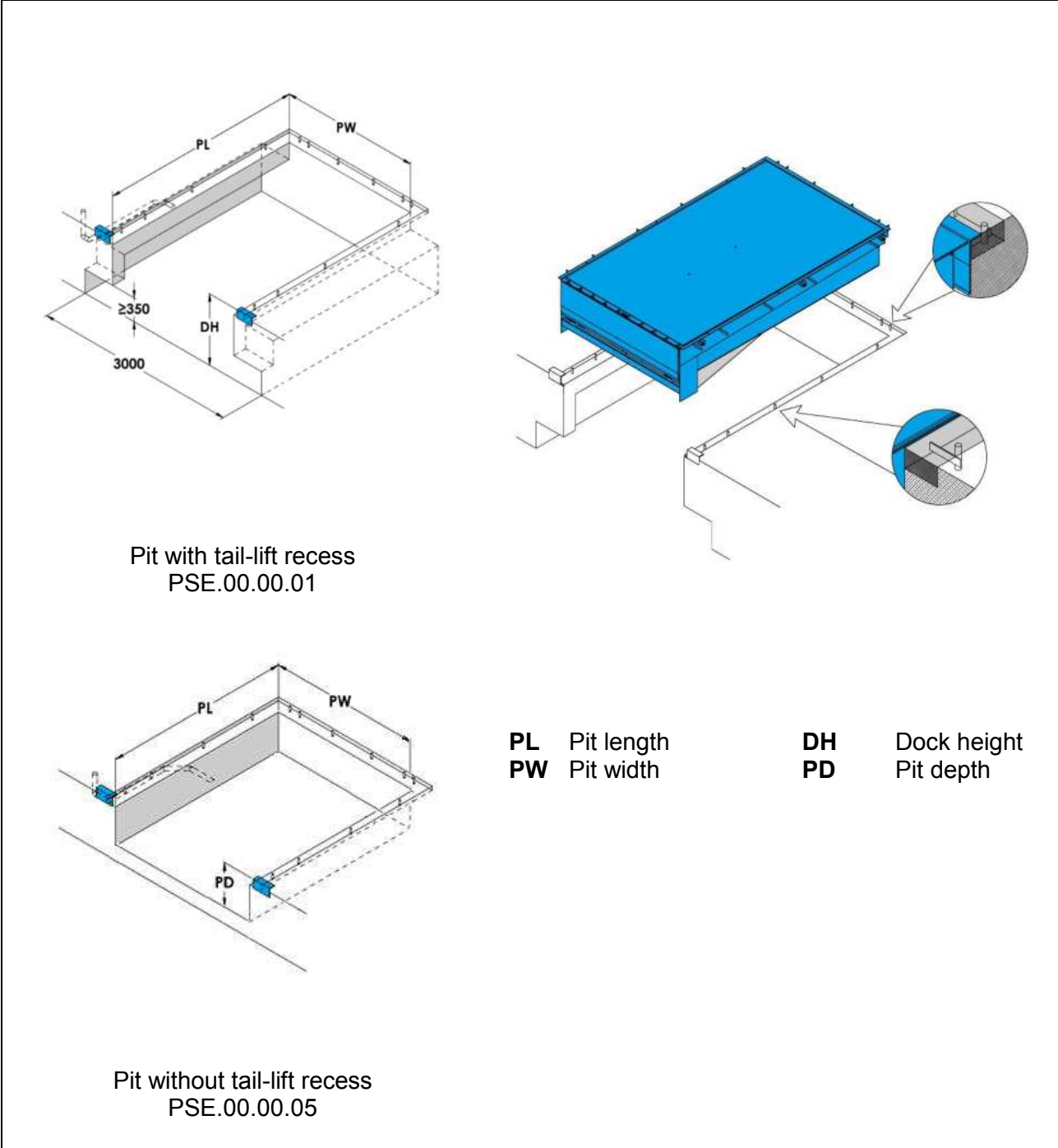

W frame (in combination with a pre-frame)

The frame can be mounted to the floor slab already before installation of the dock leveller itself. The leveller is then welded to the pre-installed frame. Pit preparations are identical for T and W type frames so that maximum flexibility is guaranteed.

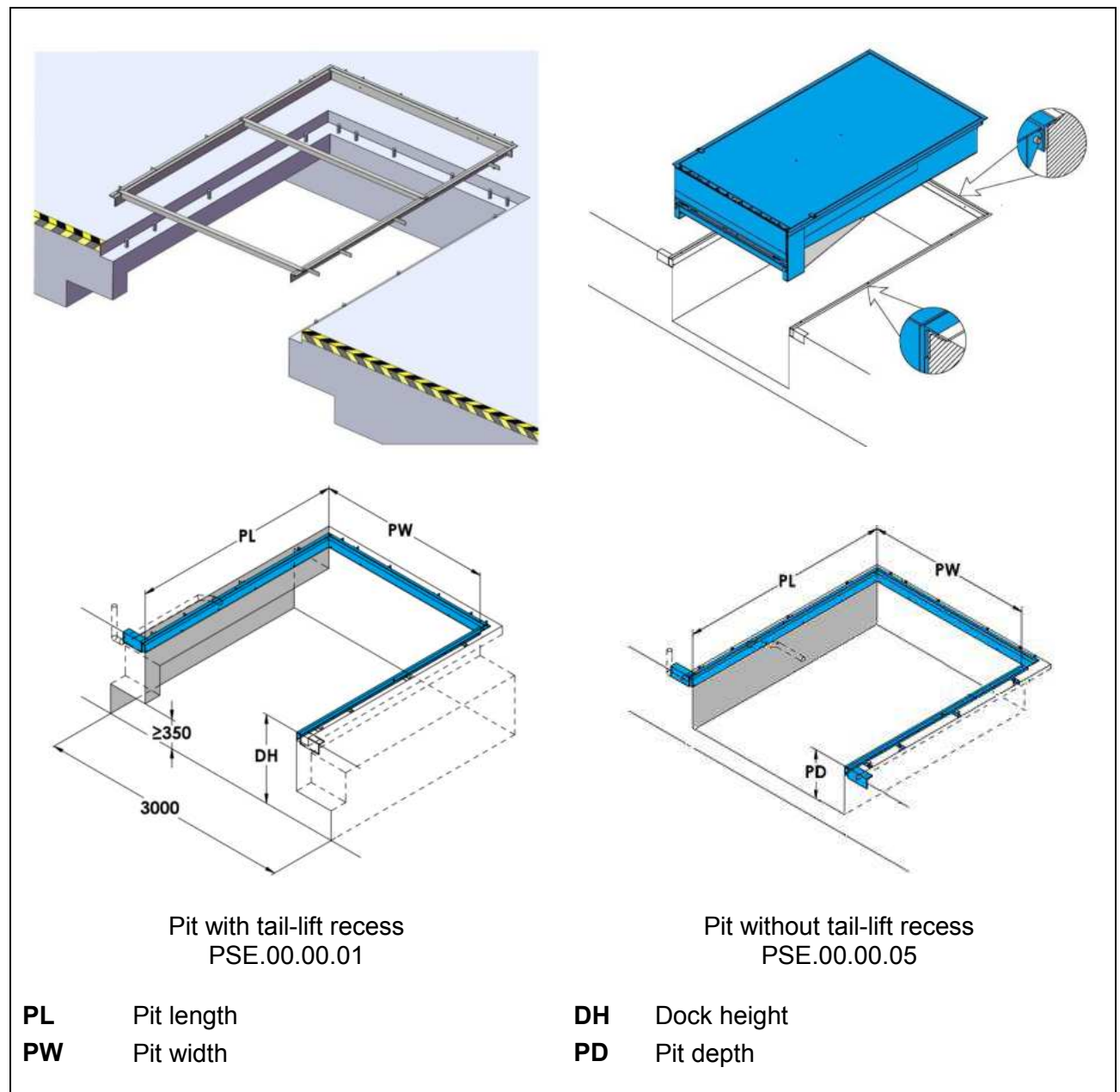

F frame (flat steel frame for leveller replacement)

This type of frame is used for easy and fast replacement of existing dock levellers. With the F-type frame the existing leveller is cut out of the pit and replaced by a new one. The existing frame is used again if it is not damaged and if its load capacity is sufficient. Thus, concrete work is not required.

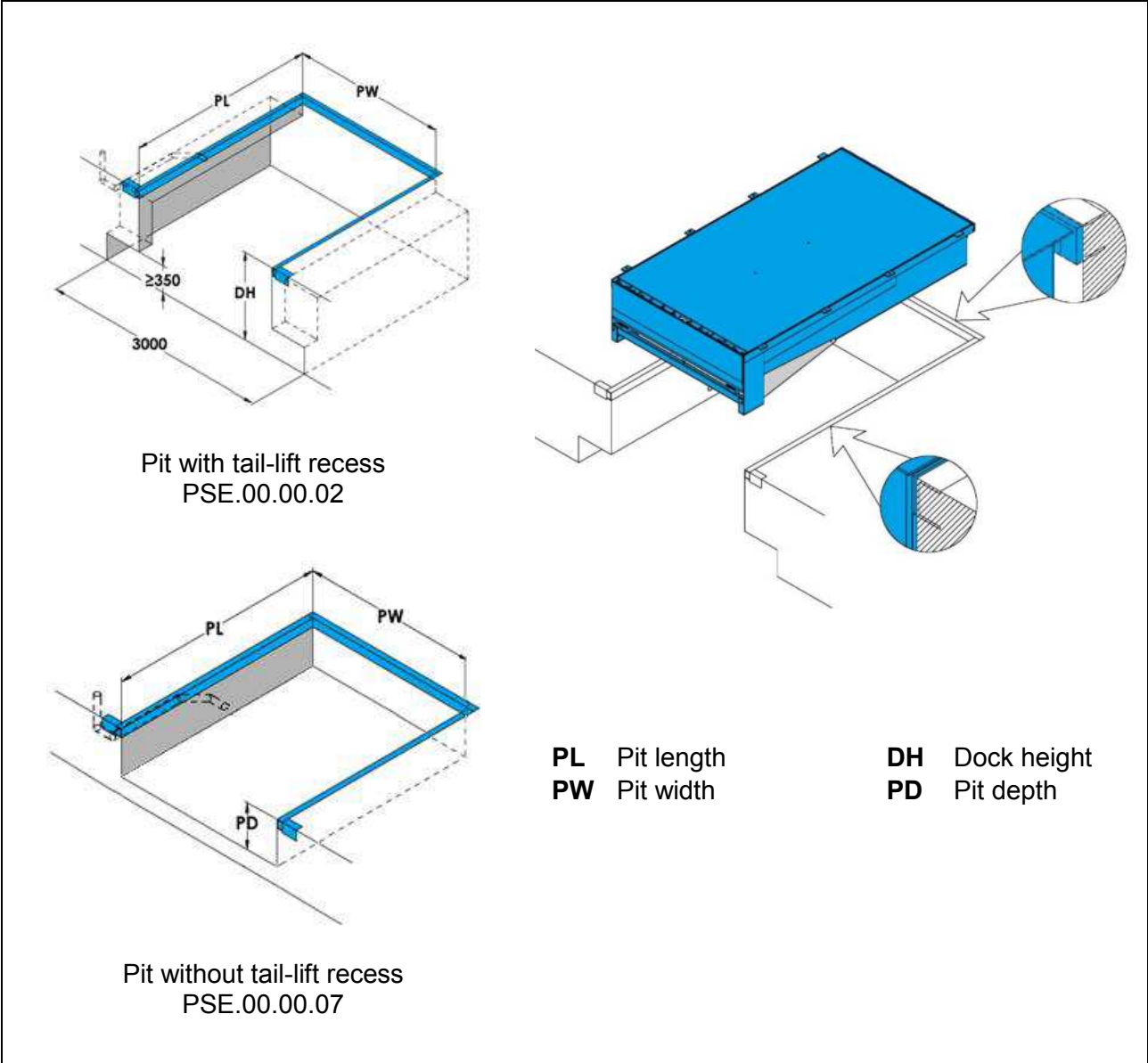

P frame (mounted in the pit)

The dock leveller frame is welded to an angle at the rear side of the pit. The advantage of this solution is the fast and easy installation of the dock leveler. This type of installation is suited only for pits without tail-lift recess.

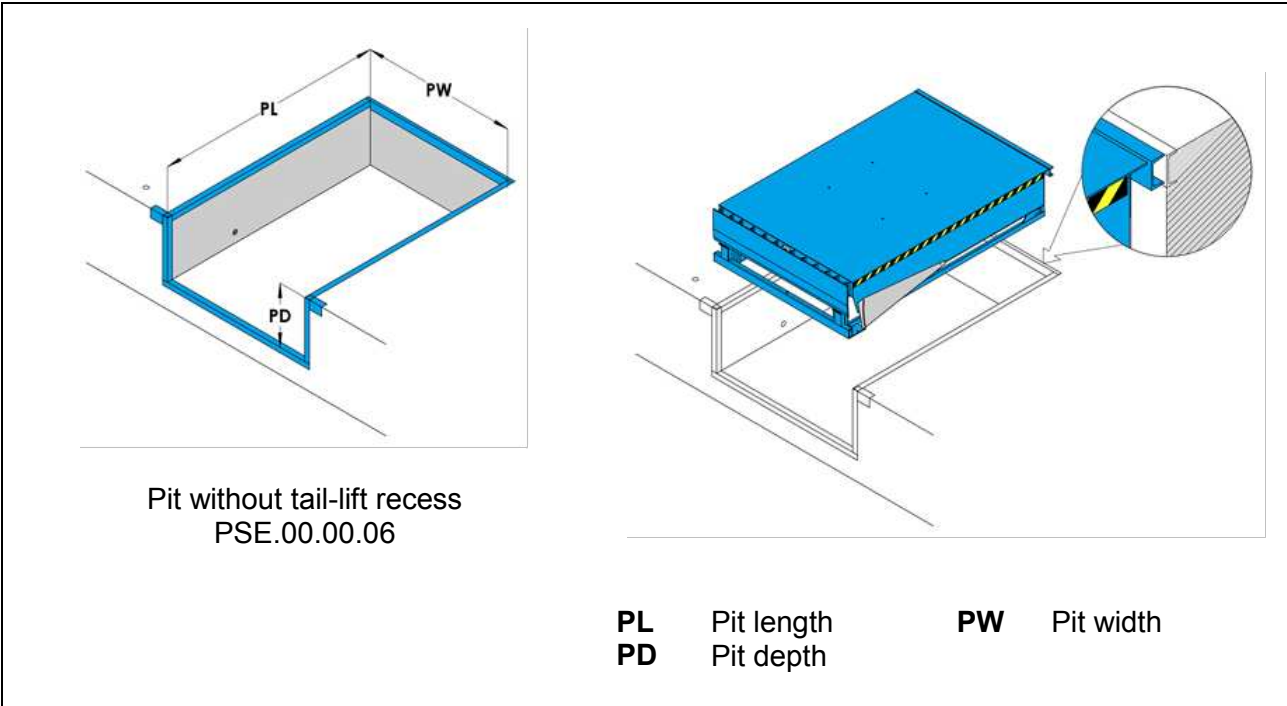

B (box)

No need to prepare a standard installation pit. Preparation of the building floor slab is much easier as boarding work is not necessary.

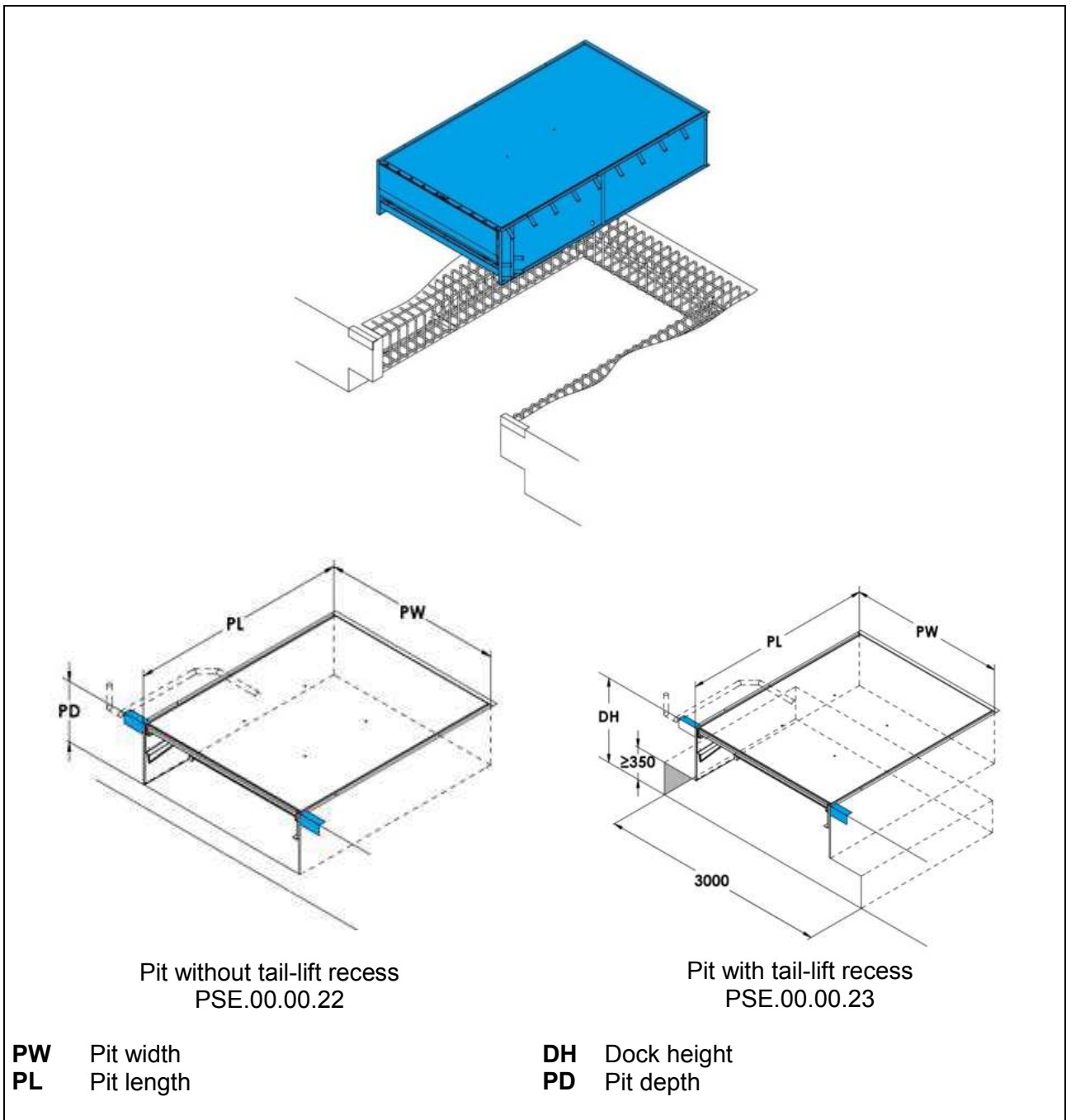

Control units

Standard DOCKController PS, with auto button (PBES 1MV 17)



Main switch

„Lift“ button to lift the platform and to swing out the lip and position it on the lorry bed

„Lift“ button to return the leveller to its rest position

Auto button (to return the leveller to its resting position by shortly pushing this button)

Possibility of connecting an industrial door

Connection possibility: door/leveller interlocking via door control unit or via a sensor (NO or NC contact)

It is not possible to connect further consumers.

Option PROMControl, with auto button, (PBES 1MV 814 01)



Main switch

„Lift“ button to lift the platform and to swing out the lip and position it on the lorry bed

„Lift“ button return the leveller its rest position

"Auto" button (to return the leveller to its resting position by shortly pushing this button)

Possibility of connecting a wheel chock, a vehicle detection system, traffic lights*, dock lights, a pneumatic dock shelter and a door locking system.
*) illustration with internal traffic lights option

Option PROMControl, with auto button, (PBES 1MV 814 05)



Main switch

„Lift“ button to lift the platform and to swing out the lip and position it on the lorry bed

„Lift“ button return the leveller its rest position

"Auto" button (to return the leveller to its resting position by shortly pushing this button)

Possibility of connecting a wheel chock, a vehicle detection system, traffic lights, dock lights, a pneumatic dock shelter and a door locking system.

Including door operation button (24 VDC)

Accessories

Buffers

Fixed buffers as well as movable buffers are designed to absorb impact during the docking process protecting both the vehicle and the docking system. All rubber elements of our PROMStahl buffer series are made of high-quality rubber ensuring a long service life.

Fixed-position buffers

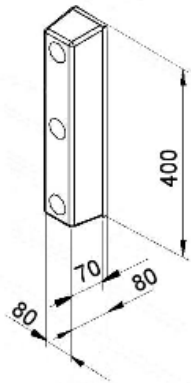

PGF 70

Rubber element (thickness 70 mm) with plate (hot-dip galvanized)

Standard high-quality rubber buffer with a high resistance to wear and tear for lower loading frequencies

PGF 90

Rubber element (thickness 90 mm) with plate (hot-dip galvanized)

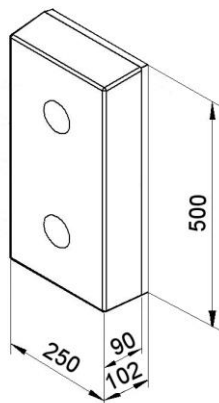

PGF 140

Rubber element (thickness 140 mm) with plate (hot-dip galvanized)

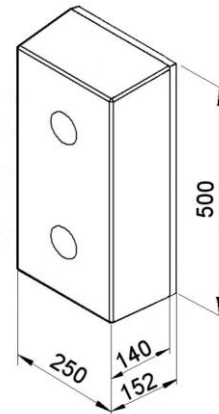

PGF 90 and PGF 140 are designed for extremely high impact forces

Height-adjustable buffers

PGV 90
Buffer with vertical guide
(rubber element: thickness 90 mm)

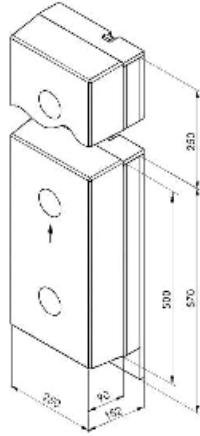

PGV 140
Buffer with vertical rail guide
(Rubber element: thickness 140 mm)

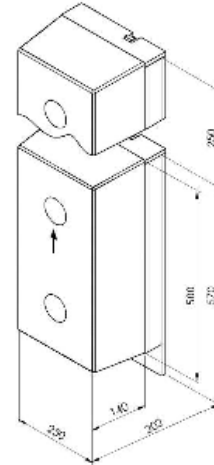

These buffers are used for loading and unloading of vehicles whose lorry beds are higher than dock level. Height-adjustable buffers can be lifted by up to 250 mm above dock edge. During loading and unloading the buffer adjusts to the lorry's vertical movements. It moves up to 50 mm upwards and 250 mm downwards. Thus, the buffer's wear is reduced to minimum and its durability is extended. After docking the buffer can be fixed at dock level so that the lorry tailgates can be opened.

Floating buffers

PGB 90
Buffer with vertical guide
(Rubber element: thickness 90 mm)

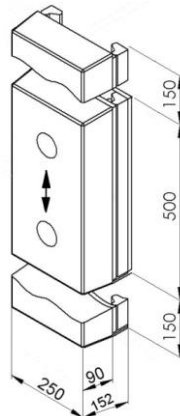

PGB 140
Buffer with vertical rail guide
(Rubber element: thickness 140 mm)

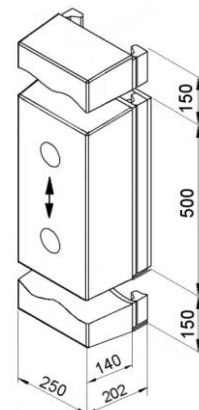

These buffers have the highest possible durability. They follow the lorry's vertical movements by 150 mm upwards and 150 mm downwards so that the buffers' wear is almost reduced to zero.

Buffers with protective housing

PGFS 90
Buffer with protective housing
(rubber element: thickness 90 mm)

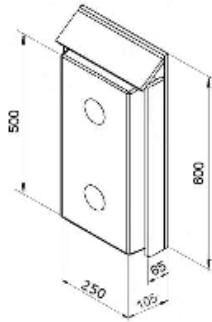

PGFS 140
Buffer with protective housing
(rubber element: thickness 140 mm)

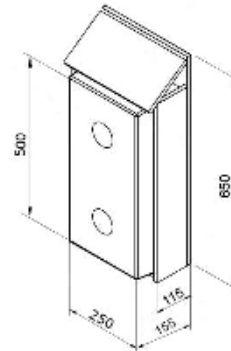

For higher impact loads buffers with protective housing are recommended. The sloped protective plate prevents the buffers from being heavily damaged. Thanks to the lateral flat steel guides the fixing bolts of rubber buffers are optimally protected against shearing.

Spring-steel buffer

PGS 600
Spring-steel buffer with plate (hot-dip galvanized)
Spring-steel plate (t=15 mm) and rubber buffer (Ø 130 mm)

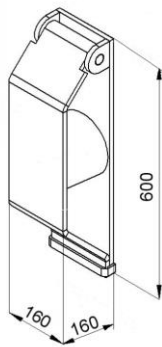

PGS 800
Spring-steel buffer with plate (hot-dip galvanized)
Spring-steel plate (t=15 mm) and rubber buffer (Ø 130mm)

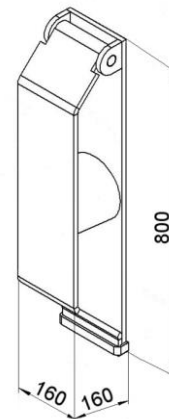

Spring-steel buffers provide optimum protection for heavy-duty loading and unloading. These buffers stand out for their excellent shock-absorbing characteristics, maximum resistance to wear and long service life.

During loading/unloading only the buffer steel plate gets into contact with the vehicle. Thus, normal tear of the surface caused by the vehicle's height movements is excluded. Costly buffer replacement is avoided and operating costs are reduced.

The spring-steel buffer is either welded to the frame or dowelled to the leveller.

Optionally, it is possible to mount the buffer 200 mm above the dock edge by means of a support.

Wheel chock



The PZK wheel chock equipped with a position-dependent ultrasonic sensor and connected to the control unit via a robust cable guarantees safety during the whole loading and unloading process. As soon as one of the rear wheels of the lorry is stopped by means of the wheel chock, the leveller control function is “released” so that operation of the dock leveller can be started.

Traffic lights



Inside and outside traffic lights represent a reasonable completion of the docking station. It is recommended to provide the loading station not only with a wheel chock but also with a traffic lights system.

PROMStahl PBEA traffic lights systems assure communication between the lorry driver and the warehouse staff. They show the driver when the docking station can be approached and left safely. The traffic lights are connected to the PROMStahl control unit and adjustments/programming can be adapted to your individual requirements.

Dock light



In general, the danger of accidents during loading/unloading is very high due to bad lighting of the docking area. PROMStahl dock lights provide the best solution for perfect lighting of the docking area and the vehicle lorry bed.

Wheel guides



Wheel guides help the truck driver to reverse to the loading bay without any complicated maneuvering actions. They are installed on yard level, either by being cast directly into concrete (types PEK and PEKE) or by being bolted on the ground (types PEF and PEFE); they represent a good and reasonable investment into the safety at your loading bay.

Electrical preparations (by others)

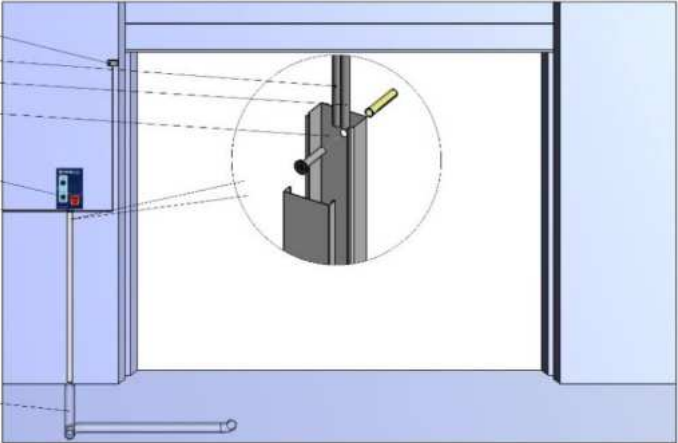

The diagram illustrates the electrical setup for a door/dock leveller. It shows a side view of the leveller mechanism with various electrical components and their connections. A circular inset provides a detailed view of the leveller's internal electrical terminal block. The components are numbered 1 through 7:

- 1 Electrical control unit (included in the scope of delivery)
- 2 Cable conduit (by others)
- 3 Wire conduit, min. internal diameter 50 mm, angled pipe $\leq 45^\circ$ (by others)
- 4 Mains supply:: 3 / N / PE AC 50 Hz
400 V/ CEE 16 A
Mains fuse: D0 10 A gL
Motor power: 0,75 kW
- 5 Cable: 3 x 0,75 mm²
- 6 Motor cable: 4 x 1,5 mm²
- 7 Door/dock leveller light sensor *)

*) Option