

# Wicket- and Side-doors 40 / 60 mm

For keeping people and goods apart

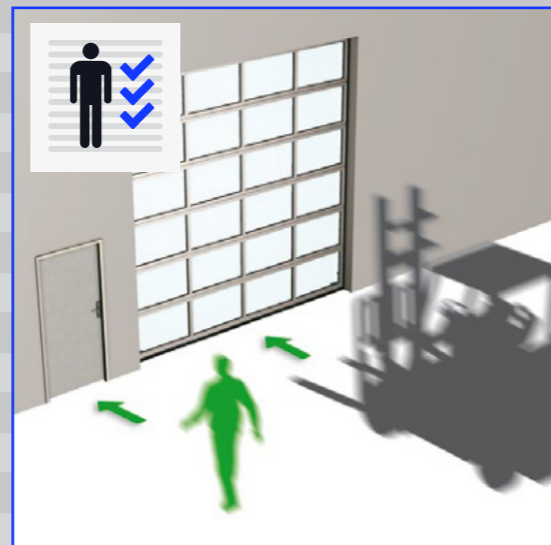

While a wicket door can be built into an ALU or ISO NextGen door, we recommend that wherever possible pedestrian traffic and goods traffic be kept apart. In other words, a permanent wicket door in the façade, separate from the sectional door, or a permanent wicket door next to the sectional door. The wicket door can be built into the sectional door, but this may affect the door's stability. It also presents limitations in terms of the door's width, height and threshold height, as a result of which the gate may not meet the current legal requirements for an emergency exit. Always discuss your plans with the local authorities so you can be sure you're choosing the right wicket door.



Completely separate doors for pedestrians and goods.

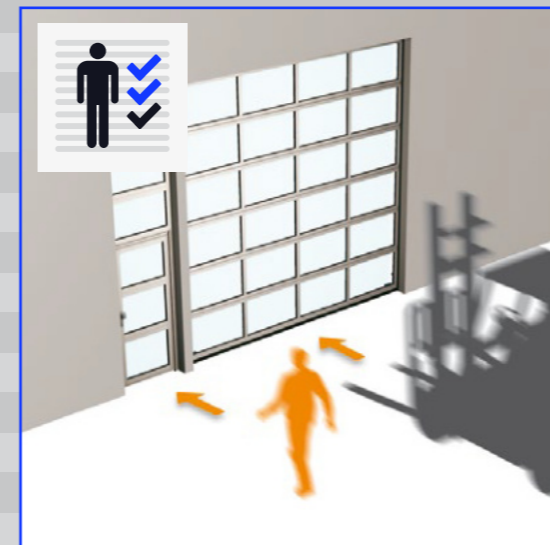

Separate doors for pedestrians and goods, but in the same opening structure.

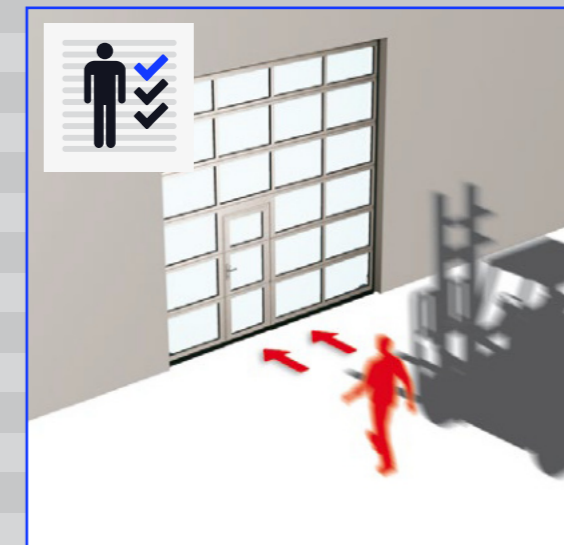

Wicket door for people built into a sectional door for goods.

## Permanent wicket door next to the sectional door

The advantage of a permanent wicket door is that the doors for pedestrians and goods are completely separate.

This increases safety, ease-of-use and the stability of the sectional door.

A permanent wicket door is installed in the façade next to the sectional door, where the design and panel structure of the wicket door and top panel match the structure of the sectional door, unifying them and making them both architecturally and aesthetically pleasing.

### Section seals

The sections of the ALU 60 door are specially sealed to make them completely wind and waterproof. Any heat transmission is prevented by the special insulation profiles.

### Choose the right door

A permanent wicket door can open both inwards and outwards and you can choose between a left-hinged DIN standard door or a right-hinged DIN standard door. If the wicket door is also to be used as an emergency exit, the door must open outwards.

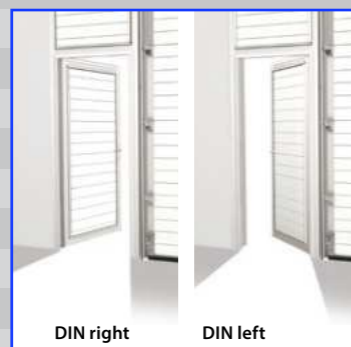

### Installation onto or in the opening

A sectional door is always built against the interior side of the opening, so if you wish to install a permanent door in the same façade, NextGen will likewise always install it behind the opening. This has two advantages: firstly the doors are aligned, and secondly the width of the wicket door is 810 mm ( $1,000 + 50 - 240 = 810$  mm) for a 1,000 mm opening.

The first aspect is aesthetically pleasing, while the second means a gain of 60 mm compared to when it is installed in the actual opening.

If the wicket doorway is installed in the opening itself, the wicket door will stand forward from the sectional door and its width will only be 750 mm ( $1,000 - 10 - 240 = 750$  mm) in the same 1,000 mm opening.

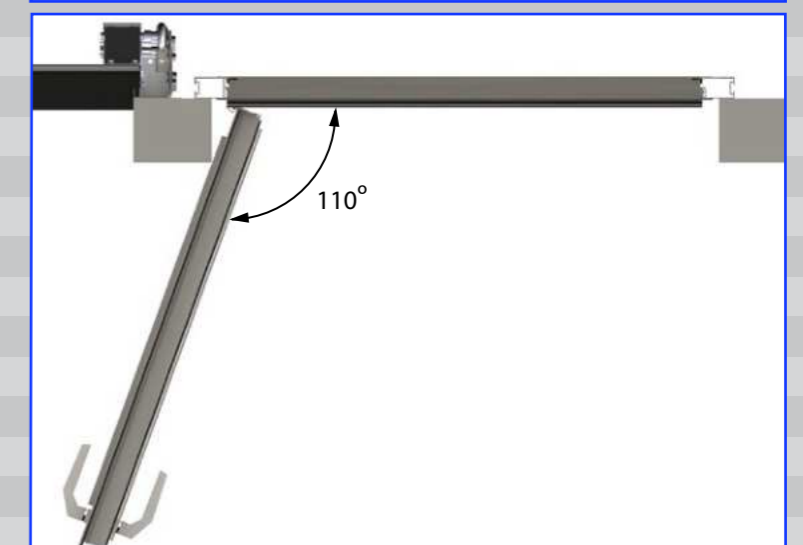
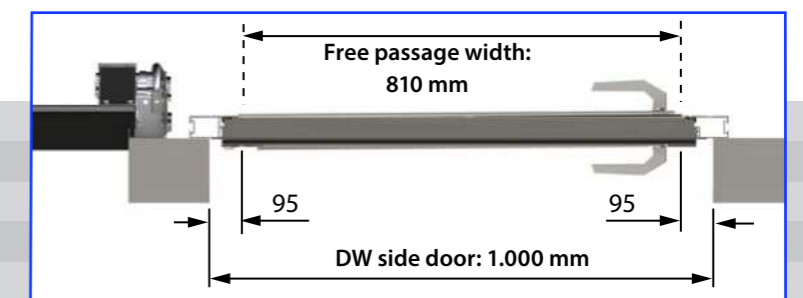

## Wicket door built into the sectional door

If you cannot install a permanent wicket door in the façade of your building, NextGen can build a wicket door into the sectional door. We offer various options for this, all of which meet the very highest structural, aesthetic and safety requirements. The built-in wicket door has a sophisticated integrated hinge system, an accurately-aligned locking system with stabilising pins and an integrated safety switch. Three choices are available for the threshold height: 16, 110 and 195 mm.



### Aesthetically appealing wicket door

NextGen recently made significant improvements to its wicket door design, the main one being the integration of the hinge system into the sectional door. This means the fastenings are no longer visible on the exterior and the standard ALU wicket door profiles do not protrude as much.

### Optional extra: coloured wicket door profiles

If you choose a coloured ISO or ALU sectional door with a built-in wicket door, the wicket door profiles do not have to have the same colour as the door. This option is up to you, and while some people prefer a clearly visible wicket door, others like theirs to be less conspicuous. NextGen offers you both options.

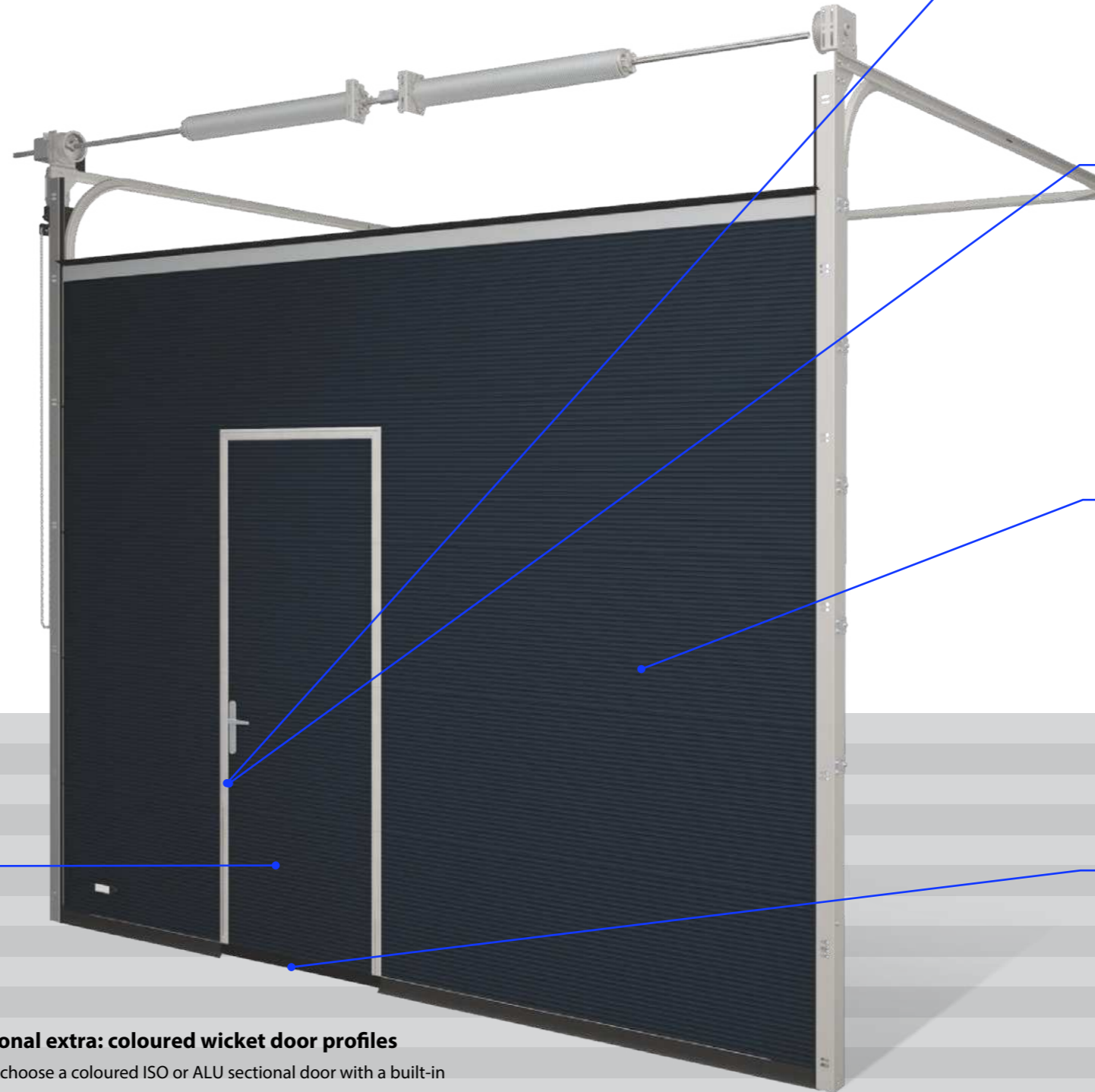

### Integrated wicket door switch

The wicket door switch, which is fitted under the safety catch, is an integrated safety device that prevents the sectional door from being operated when the wicket door is open.

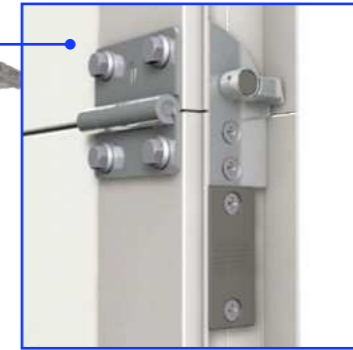

### Stabilising pins

The wicket door is held in perfect position by the stabilising pins. This means that the door will never "droop". The pins also create a more effective seal between the wicket door and the door. The magnetic contact of the wicket door switch is fitted beneath the pin.

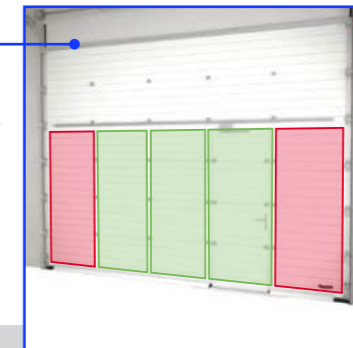

### Divider

A wicket door can never be positioned in the outermost parts of a sectional door, as this would affect its stability. The picture shows where the door can and cannot be installed. Wicket doors can be installed in sectional doors with a maximum door panel width of 6,000 mm. If you have a wider door, you will have to consider alternative options.



### 16 mm threshold

Since October 2019, the wicket door has been available in a height of 16 mm and a width of 111 mm and has the option of feeding a 7-core cable twice (in connection with the locking plate). A threshold with this low height complies under certain conditions with national guidelines regarding escape routes.

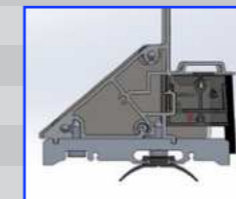

## Integrated wicket door as an emergency exit

If you intend to use the built-in wicket door as an emergency exit, talk to the local authorities first and enquire about the regulations. The authorities stipulate the conditions that the wicket door must meet, depending on the number of people working or otherwise present in the building. As a rule, four aspects determine whether a wicket door is suitable as an emergency exit: the type of lock, the door width, the door height and the threshold height. Lastly, an integrated wicket door must always open outwards, as is required for any door that serves as an emergency exit.



### Panic lock

A wicket door that is to function as an emergency exit must be fitted with a panic lock. Various types of panic locks are available. A wicket door with a panic lock can always be opened using the latch on the inside, even when the deadbolt is secured.

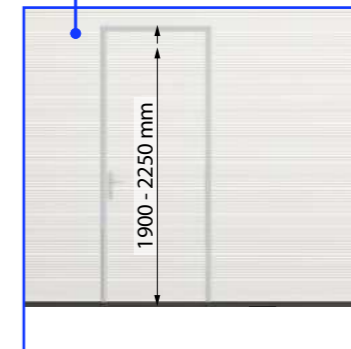
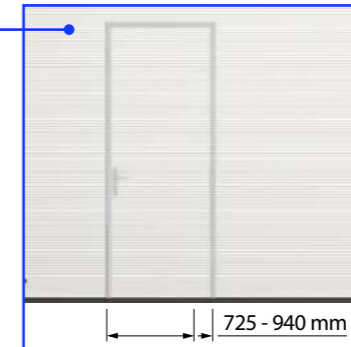

### Door width and height

The legislative and inspection bodies stipulate that a wicket door which is to serve as an emergency exit must be of a minimum width and height, according to local or national regulations. The maximum width of an integrated wicket door is 940 mm and the maximum height is 2,250 mm. Talk to your local authorities if your wicket door is to serve as an emergency exit.

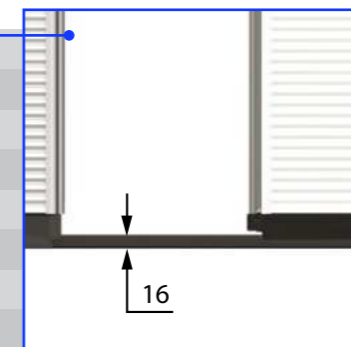

### 16 mm threshold

Since October 2019, the wicket door has been available in a height of 16 mm and a width of 111 mm and has the option of feeding a 7-core cable twice (in connection with the locking plate). A threshold with this low height complies under certain conditions with national guidelines regarding escape routes.

